



**ELECTRIC  
SERVICE  
GUIDELINES  
(For Indiana)**

**FOR  
COMMERCIAL / INDUSTRIAL  
DEVELOPMENTS**

# ELECTRIC SERVICE GUIDELINES FOR COMMERCIAL/INDUSTRIAL DEVELOPMENTS



<b>INTRODUCTION</b> .....	<b>2</b>
<b>WHAT YOU NEED TO OBTAIN ELECTRIC SERVICE</b> .....	<b>3</b>
<b>TEMPORARY ELECTRIC SERVICE REQUIREMENTS</b> .....	<b>4</b>
<b>CUSTOMER COSTS</b> .....	<b>5</b>
<b>PROJECT DESIGN AND CONSTRUCTION</b> .....	<b>6</b>
<b>RIGHT-OF-WAY</b> .....	<b>7</b>
<b>CUSTOMER FACILITY SPECIFICATIONS</b> .....	<b>8</b>
<b>METERING</b> .....	<b>10</b>
<b>EXHIBIT “A”</b> .....	<b>11</b>
COMMERCIAL/INDUSTRIAL ELECTRIC SERVICE INFORMATION .....	11
<b>EXHIBIT “B”</b> .....	<b>12</b>
RATE INFORMATION SHEET .....	12
<b>EXHIBIT “C”</b> .....	<b>13</b>
PRE-CONSTRUCTION MEETING REQUIREMENTS .....	13
<b>EXHIBIT “D”</b> .....	<b>14</b>
SERVICE REQUIREMENTS FOR UNDERGROUND PRIMARY ELECTRIC SERVICE FROM AN OVERHEAD DISTRIBUTION LINE TO COMMERCIAL OR INDUSTRIAL CUSTOMERS .....	14
<b>EXHIBIT “E”</b> .....	<b>16</b>
PADMOUNT EQUIPMENT CLEARANCES FROM BUILDINGS .....	16
<b>EXHIBIT “F”</b> .....	<b>19</b>
INSTALLATION REQUIREMENTS FOR THREE-PHASE PADMOUNT TRANSFORMER FOUNDATIONS FOR COMMERCIAL OR INDUSTRIAL CUSTOMERS.....	19
<b>EXHIBIT “G”</b> .....	<b>21</b>
CONSTRUCTION DETAILS FOR CUSTOMER INSTALLED ELECTRIC FACILITIES .....	21
<b>EXHIBIT “H”</b> .....	<b>22</b>
CONSTRUCTION DETAILS FOR CUSTOMER INSTALLED ELECTRIC FACILITIES PADMOUNT EQUIPMENT PROTECTION.....	22

# ELECTRIC SERVICE GUIDELINES FOR COMMERCIAL/INDUSTRIAL DEVELOPMENTS



## INTRODUCTION

### **Duke Energy**

1000 East Main Street  
Plainfield, IN 46168-1782

1-800-521-2232

### **Introduction**

*This publication is a guide to the Company's requirements and does not cover all rules and regulations. It is intended to promote uniformity throughout the Company's system and to provide a satisfactory interface guide for the customer's electric service equipment at the service point.*

Duke Energy (referred to as the "Company") provides this publication to assist all commercial and industrial customers in planning for and obtaining prompt and satisfactory electric service.

Any references to Energy Delivery in this publication include the Regulated Business Unit of Duke Energy.

The format of this manual allows for updating of information and drawings. Please remember it is the customer's responsibility to obtain and maintain a current version of this publication.

### **Disclaimer**

*This publication is for informational purposes only and in no way shall this publication be construed to impose any liability upon the Duke Energy or its subsidiary or affiliated companies (collectively referred to as the "Company"). The Company makes no warranties or representations in this publication expressed or implied, including but not limited to merchantability and fitness for a particular purpose.*

Duke Energy

# ELECTRIC SERVICE GUIDELINES FOR COMMERCIAL/INDUSTRIAL DEVELOPMENTS



## THE FIRST STEPS:

### WHAT YOU NEED TO OBTAIN ELECTRIC SERVICE

#### **Notification**

Duke Energy relies on you, the customer, to inform us of your plans for construction. The information detailed on the Commercial/Industrial Electric Service Information sheet (Exhibit "A") should be submitted with your project plans. Please give us sufficient notice so that we can meet your construction schedule. On average we suggest you provide six (6) months advance notice prior to construction. In order to meet your deadlines, coordination of our schedules is essential. Please provide realistic time schedules and inform us of any changes in project scope or changes to your schedule as soon as you become aware of them. You should contact the other utilities to determine their individual requirements.

#### **Permanent Electric Service**

An application for permanent electric service must be made prior to the installation of electric service. To apply for temporary and/or permanent electric service, you should contact Duke Energy at 1-800-774-0246.

#### **Load Data**

Duke Energy will need an accurate listing of electrical loads to be connected to the electric service. List and provide as much operating data as possible on the Commercial/Industrial Electric Service Information sheet (Exhibit "A"). Use the back of the sheet to list equipment nameplate data on motors, welders, adjustable speed drives, sensitive electronic loads, etc., that you plan to install. We will review your list of equipment and evaluate its potential to adversely affect the quality of power. Motors larger than 50HP may be required to have some form of reduced voltage starting to limit objectionable flickers on Duke Energy's system. Duke Energy may also require you to install additional mitigation equipment to reduce or eliminate objectionable power fluctuations that occur due to your operation.

#### **Rate Selection**

When more than one rate schedule is available, Duke Energy will provide you with the applicable rates for your decision. For more information on rates, see the attached Rate Information Sheet (Exhibit "B"). You can also obtain copies of rates by visiting [www.Duke-Energy.com](http://www.Duke-Energy.com), entering our "Business Services" page and clicking on "Tariffs."

# ELECTRIC SERVICE GUIDELINES FOR COMMERCIAL/INDUSTRIAL DEVELOPMENTS



## TEMPORARY ELECTRIC SERVICE REQUIREMENTS

### **Standard Overhead Temporary Service**

When a temporary overhead service is requested and an overhead secondary voltage is located within 100 feet of the customer's meter structure, the customer shall pay a non-refundable payment of \$200 to Duke Energy within 30 days of invoice. The installation must allow for proper clearances in accordance with the National Electric Safety Code (NESC).

### **Standard Underground Temporary Service**

When a temporary underground service is requested and an existing padmount transformer or secondary junction cabinet is located within five feet of the customer's meter structure, the customer shall pay a non-refundable payment of \$120 to Duke Energy within 30 days of invoice. The customer shall coil at least 10 feet of conductor for Duke Energy to make the final connections.

### **Non-Standard Temporary Service**

When a temporary service is requested which requires facilities in addition to those listed above, the customer shall also pay a non-refundable payment to Duke Energy for those additional facilities prior to construction in an amount equal to their estimated construction and retirement costs.

# ELECTRIC SERVICE GUIDELINES FOR COMMERCIAL/INDUSTRIAL DEVELOPMENTS



## CUSTOMER COSTS

### **Service Deposit**

In cases where no credit history for a customer exists, Duke Energy may require a service deposit equal to two (2) times the estimated monthly revenue for the requested service.

### **Revenue Credit**

The revenue credit for service to a new development is two and a half (2.5) times the estimated annual revenue. The estimated annual revenue is based upon anticipated electrical usage.

### **Line Extension Advance Deposit (Lead) for Line Construction**

If the estimated construction costs to provide standard electrical service exceeds the revenue credit, Duke Energy may require the customer to pay a Line Extension Advance Deposit (LEAD) equal to the difference between the estimated construction cost and revenue credit prior to the start of construction.

### **Relocations Due to Acceleration/De-Acceleration Lanes**

If Duke Energy facilities need to be relocated due to the installation of new acceleration or de-acceleration lanes, the customer will be required to (1) furnish Duke Energy with a suitable relocation area and with written easement rights that are acceptable to Duke Energy and (2) pay the estimated cost to relocate the Duke Energy facilities. Payment of the estimated relocation cost is required prior to relocation of electrical facilities.

# ELECTRIC SERVICE GUIDELINES FOR COMMERCIAL/INDUSTRIAL DEVELOPMENTS



## PROJECT DESIGN AND CONSTRUCTION

### **Project Design**

The electric utility design will be developed by Duke Energy and based upon a standard electrical service to meet the expected electrical demands.

### **Main Disconnect**

For service voltages less than 1000V, disconnects may be limited to 3000 A.

### **Pre-Construction Meeting**

Prior to the start of electric utility construction, a pre-construction meeting may be scheduled between the customer, Duke Energy representatives, and other involved utility companies. See the attached Pre-Construction Meeting Requirements sheet (Exhibit "C") for a list of those items that are to be completed by the customer prior to the meeting.

### **Transformer – Duke Energy Owned Applications**

The transformer will be furnished and installed by Duke Energy. The maximum number of service conductors that can be installed in a padmount transformer is eight runs of #750mcm copper. If additional service conductors are needed, the customer will be required to furnish and install a secondary buss bar cabinet to accommodate the conductors.

### **Excess Facilities**

If the customer requests a service that requires the installation of equipment and facilities that are in excess of what Duke Energy considers a standard service, the customer will be required to pay for the cost of such excess facilities.

# ELECTRIC SERVICE GUIDELINES FOR COMMERCIAL/INDUSTRIAL DEVELOPMENTS



## RIGHT-OF-WAY

### **Easements**

Duke Energy may require the customer to provide a written easement for the Duke Energy-owned electrical facilities at no charge to Duke Energy. All Duke Energy easements shall be shown on the recorded development plat along with the proper legal description of the easement. Duke Energy will record the written easements.

### **Construction Area**

It is the customer's responsibility to clear the Duke Energy easement area and service route of construction materials, dumpsters, dirt piles, trees, fences, etc. for Duke Energy equipment and personnel before installation can begin. The customer is responsible to protect shrubs, trees, grass and other landscaping during construction. All Duke Energy excavated areas will be backfilled and mounded using onsite excavated materials by Duke Energy. Any (customer-requested) special backfill material is the responsibility of the customer and must be onsite at the time of Duke Energy excavation.

### **Vegetation Management**

Duke Energy reserves the right to remove or maintain any vegetation on or adjacent to the easement for the purpose of providing safe reliable electric service to the customer and the general public.

# ELECTRIC SERVICE GUIDELINES FOR COMMERCIAL/INDUSTRIAL DEVELOPMENTS



## CUSTOMER FACILITY SPECIFICATIONS

### **Conduit Specifications**

All conduits furnished and installed by the customer shall meet the following criteria:  
Shall be made from Polyethylene (PE) or Polyvinyl Chloride (PVC)  
Appropriate National Electrical Manufacturers Association (NEMA) standards for electric utility installations  
Suitable for use with underground electric distribution cables rated at 90°C  
Shall have a UL listing  
Shall have a schedule 40 rating clearly printed on the exterior surface

### **Conduit Bends**

All conduit bends shall be made of PVC. All bends shall be 90° or less “Sweep” bends with a minimum radius of 36 inches. Field made bends are not acceptable.

### **Primary Conduit**

The customer shall provide and install all required conduits for underground primary cable. The minimum inside diameter of the conduit shall be four (4) inches. Larger conduit may be required for some installations. Duke Energy will determine the conduit size and locations.

Conduit shall be installed at least 30 inches deep (no more than 36 inches deep at the endpoints.) The conduit route shall have a maximum of four (4) conduit bends and shall be approved by Duke Energy prior to installation. If the proposed conduit route exceeds 600 feet the customer shall provide an alternate cable route or provide and install an approved splice box or manhole.

The customer is required to install a continuous pull cord in each conduit run and securely cap both ends of the conduits with duct plugs or caps. Duct caps or plugs are NOT to be glued in place.

The customer must also mark the location of the ends of the conduit by placing a stake above ground over the end of the conduit. The stake will be labeled “End of Duct.” The integrity of the conduit system is the customer’s responsibility. The customer should contact other utilities to determine their specific conduit requirements. See the attached Service Requirements for Underground Primary Electric Service From An Overhead Distribution Line to Commercial or Industrial Customers (Exhibit “D”) for typical installation details.

### **Service Conduit**

The customer will furnish and install conduit from its building to the service pole, secondary pedestal, or padmount transformer from which service will be provided.

# ELECTRIC SERVICE GUIDELINES FOR COMMERCIAL/INDUSTRIAL DEVELOPMENTS



## CUSTOMER FACILITY SPECIFICATIONS CONTINUED...

### **Transformer Pad**

The customer shall provide a transformer pad in accordance with Duke Energy standards for all installations requiring a three-phase padmount transformer. The following items are to be approved by Duke Energy before installation:

The transformer installation must be located where it is accessible by standard Duke Energy construction and maintenance equipment. There must be permanent vehicle access within 10 feet of the three-phase transformer pads and within 25 feet of single-phase transformer pads. Access routes across non-paved areas require an eight-inch thick gravel base.

Transformers or other service equipment must be located away from buildings and from building openings as required by local codes and the National Electric Code (NEC). A 10-foot clear zone must also be maintained in front of access doors to Duke Energy equipment to allow for operation and maintenance activities. Shrubbery or storage of equipment or material is prohibited in the clear zone. See the attached Padmount Equipment Clearances From Buildings sheet (Exhibit "E").

The customer shall install the transformer pad on a layer of firmly compacted granular backfill. Primary and service conduits and bends entering the transformer pad must be installed at the same time as the transformer pad at least to the point where they extend beyond the edges of the transformer pad. The pad is to be level and flat in all directions. See the attached Installation Requirements for Three-Phase Padmount Transformer Foundations for Commercial or Industrial Customers (Exhibit "F") and Construction Details for Customer Installed Electric Facilities (Exhibit "G").

The customer shall protect padmount transformer installations from damage by vehicles. See the attached Construction Details for Customer Installed Electric Facilities Padmount Equipment Protection (Exhibit "H").

### **Other Underground Facilities**

It is recommended that the customer extend water and sewer connections beyond the electric utility trench where possible. This reduces the chance of the customer incurring additional charges associated with damage to Duke Energy facilities when installing other utility services.

# ELECTRIC SERVICE GUIDELINES FOR COMMERCIAL/INDUSTRIAL DEVELOPMENTS



## METERING

### **Meter Base Location**

Duke Energy reserves the right to approve the location of all electric service delivery points and the location of electric meter bases. This location will generally be at the padmount transformer.

### **Telephone Line Requirements**

The customer is required to provide a telephone line at the utility meter point for all services with a demand of 500 kW or greater. The purpose of the telephone line is to provide the capability to remotely interrogate the meter for billing purposes. A dedicated line is required. The customer is responsible for monthly charges. In cases where access to a telephone line is not available, please contact Duke Energy.

If a smaller service is installed and future load growth is anticipated that will increase the service to more than 500 kW, it is strongly recommended that the telephone service be installed during the construction of the initial electric service.

EXHIBIT "A"

**COMMERCIAL/INDUSTRIAL ELECTRIC SERVICE INFORMATION**

Date \_\_\_\_\_ Acct# \_\_\_\_\_ WMS# \_\_\_\_\_

CUSTOMER / BILLING INFORMATION – All Fields Required

- Billing Name \_\_\_\_\_
- Service Address \_\_\_\_\_
- Billing Address \_\_\_\_\_
- Billing Contact \_\_\_\_\_ Phone # \_\_\_\_\_
- Type of Business \_\_\_\_\_
- Use / Hours of Operation \_\_\_\_\_

CONTRACTOR / OTHER CONTACTS

- General Contractor \_\_\_\_\_ Phone # \_\_\_\_\_
- Electrical Contractor \_\_\_\_\_ Phone # \_\_\_\_\_
- \_\_\_\_\_ Phone # \_\_\_\_\_

SERVICE REQUIREMENTS AND LOAD DATA

- |   | Date Required | OH / UG | 1Ø    | 3Ø    | Voltage |
|---|---------------|---------|-------|-------|---------|
| <input type="checkbox"/> Temporary      | _____         | _____   | _____ | _____ | _____   |
| <input type="checkbox"/> Permanent      | _____         | _____   | _____ | _____ | _____   |
| <input type="checkbox"/> Required Plans | _____         |         |       |       |         |
- 
- |   |       |                      |                  |       |    |
|---|-------|----------------------|------------------|-------|----|
| <input type="checkbox"/> Bldg sq ft         | _____ | Connected Load Data: |                  |       |    |
| <input type="checkbox"/> Main Disconnect    | _____ | Cooling              | _____            |       | kW |
| <input type="checkbox"/> Entrance Wire Size | _____ | Heating              | _____            |       | kW |
| <input type="checkbox"/> _____              |       |                      | _____            | _____ | kW |
|   |       | 1Ø                   | 3Ø               | _____ | kW |
| <input type="checkbox"/> Largest Motor HP   | _____ | _____                | _____            | _____ | kW |
| <input type="checkbox"/> Total Motor HP     | _____ | _____                | Total Connection | _____ | kW |

MISCELLANEOUS INFORMATION

<p><b>Please send information to:</b></p> <p><b>Duke Energy</b></p> <p>_____</p> <p>Address</p> <p>_____</p> <p>City, State, Zip</p>
--

## EXHIBIT "B"

### RATE INFORMATION SHEET

Three rates are available to commercial and industrial customers:

**Rate CS** – Commercial Service is available to single-phase customers with maximum loads of 75 kW or less.

**Rate LLF** – Low Load Factor Service is available to all power service customers and single-phase customers. Typical customers include professional offices, service businesses and other single-shift operations.

**Rate HLF** – High Load Factor Service is available to all power service customers and single-phase customers with demands over 25 kW. Typical customers include convenience stores, fast-food restaurants, mall stores and other facilities operating two or three shifts or seven days a week.

**Load Factor Calculation Example:** 50 kW demand, 18,000 kWh  
 $18,000\text{kwh} / (50\text{kW} * 720 \text{ hours}) = .5$  or 50% load factor

#### Service to be Furnished

When requested by Duke Energy, the customer will provide a listing of all equipment to be operated. Duke Energy equipment has specific capacity limits; therefore, the customer will need to provide Duke Energy with adequate advance notice of any load increases. Failure to notify Duke Energy may result in the customer being liable for damage to Duke Energy property. Any unusual situation, question or use of riders that might require a written agreement should be reviewed with Duke Energy.

#### Rate Selection

Usually, more than one rate can be applied for selected service. It is the customer's responsibility to designate the chosen rate. Duke Energy will advise the customer on the most economical rate based on information available at the time service is requested. Subsequent changes in Duke Energy's rates or the customer's operations may affect which rate is economical for the customer. The customer must therefore notify Duke Energy of significant changes in the customer's energy usage and review rate option with Duke Energy annually. The customer may change their initial rate by notifying Duke Energy. The new rate selection must remain in effect for at least 12 months before another change can take place.

#### **Character of Service:**

<b>Secondary Voltages</b>	<b>Transformer Size Limits</b>	<b>Service Availability</b>
Single Phase 120/240 volts	167 KVA	OH & UG
Network and/or Designed Areas 120/208 volts, three wire	40 KVA	OH & UG
<i>Voltages listed below are not available in all locations.</i>		
Three Phase 120/208, Wye	300 KVA	OH
	500 KVA	UG
120/240 volts, Open Delta	1-50 KVA	OH
	1-100 KVA	
240 volts, Open Delta	2-50 KVA	OH
277/480 volts, Wye	500 KVA	OH
	2000 KVA	UG

For primary and transmission voltages, review with Duke Energy.

## EXHIBIT "C"

### PRE-CONSTRUCTION MEETING REQUIREMENTS

The customer shall perform the following activities prior to any pre-construction meeting.

- Mark all lot lines (notched or painted on the curb or edge of pavement)
- Have all areas in the vicinity of the electric utility trench graded to within four (4) inches of final grade
- Install the transformers pad as directed with the instructions from Duke Energy
- Install the conduit system, (conduit, manholes, bends, etc.) in accordance with Duke Energy specifications and at locations specified by Duke Energy. The conduit must have at least 30 inches of cover over the top conduit.
- Install a pull cord in each duct run
- Cap the ends of all conduit
- Conduit end points shall be a minimum of 30" and a maximum of 36" in depth.
- Mark ends of conduit with proper stakes
- Provide suitable protection of the underground electric ducts during other construction activities in the area
- Verify metering requirements including location and metering telephone line

Note: The customer needs to contact the other utilities to determine their conduit requirements.

*No trees, signs, walls, etc. should be planted or erected on the utility easement prior to or subsequent to Duke Energy's construction without prior written approval from Duke Energy.*

## EXHIBIT "D"

### SERVICE REQUIREMENTS FOR UNDERGROUND PRIMARY ELECTRIC SERVICE FROM AN OVERHEAD DISTRIBUTION LINE TO COMMERCIAL OR INDUSTRIAL CUSTOMERS

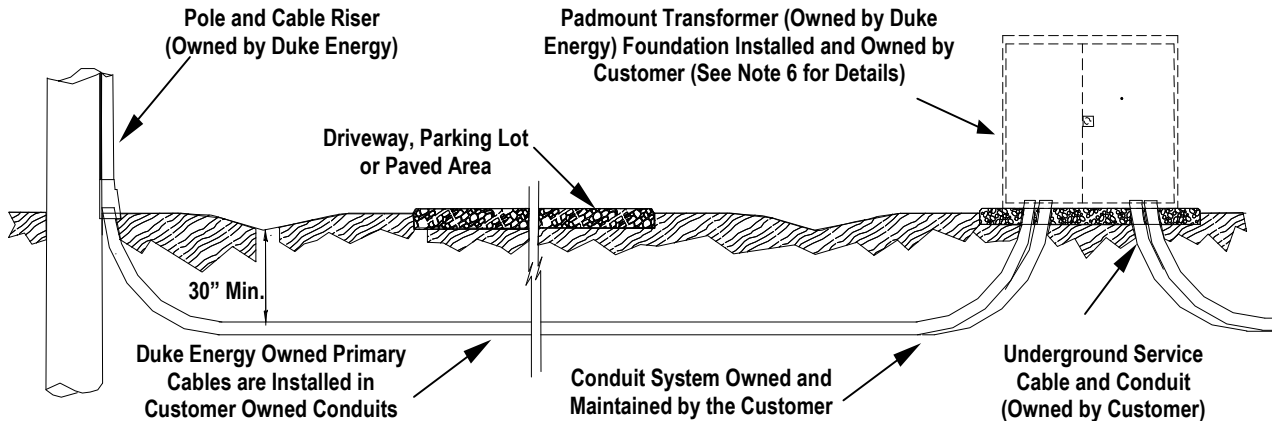

#### SERVICE REQUIREMENTS:

1. **Easements:** The customer shall provide an easement 15 feet in width for the underground electric system. The easement shall be cleared of all obstructions that may interfere with underground cable installation, operation and maintenance. The easement shall be kept clear of vegetation, buildings or any obstructions.
2. **Use by Others:** The underground conduit system containing the electric cables is for the sole use of Duke Energy.
3. **Acceptance:** The company reserves the right to refuse service to new installations that do not meet Duke Energy requirements and may elect to remove existing service cables if the customer fails to provide adequate maintenance, including operating space to customer-owned facilities.
4. **System Route and Equipment Location:** Duke Energy shall be responsible for determining the final routing for underground primary cables. The cable route must be accessible for maintenance along its entire length. The customer shall provide a level location at final grade for a padmount transformer installation as directed by the Company. The customer shall be responsible for constructing a transformer pad for three phase installations in accordance with Duke Energy requirements. The three-phase transformer pad must be located within 10 feet of a permanent driveway or other area accessible to Duke Energy construction and maintenance equipment. No part of the transformer (or transformer pad) may be within 12 feet from any combustible wall, window, or ventilation opening and 20 feet from any doorway in a building. There must be at least of three (3) feet of clearance between customer equipment or landscaping and the side of the transformer (or transformer pad) and 10 feet of clearance to the front of the transformer (or transformer pad). Local regulations may require additional clearances to padmount equipment.

5. Trench Dimensions and Clearances: The primary conduit system shall be a minimum of 30 inches (maximum of 36 inches deep at the conduit end points.) It must be at least three (3) feet away from adjacent gas pipes or water lines. It shall be at least one (1) foot away from all other underground utilities. The surface grade over the conduit system shall not be changed in any way that reduces or increases the depth of burial.
6. Materials & Labor: The customer shall provide all materials and excavation labor necessary to install the underground conduit system. This includes trenching, backfilling, installation of conduit and conduit accessories, installation of precast manholes and cable pits, installation of transformer foundations, etc.
7. Conduit: The customer shall install, own and maintain the conduit system including duct, manholes, cable pits and transformer foundations, etc.. It shall be installed in accord with Duke Energy standards. The conduit shall be made from either polyethylene (PE) or Polyvinyl Chloride (PVC) and suitable for use with underground electric distribution cables rated at 90°C. All conduits shall have a UL listing and a schedule 40 rating clearly printed on the exterior surface. For primary jacketed concentric neutral primary cables, the minimum inside diameter of the conduit shall be four (4) inches. For all other primary cables, a minimum inside diameter of six (6) inches is required. All bends shall be 90° or less "Sweep" bends with a minimum radius of 36 inches. Conduit may be direct buried if local permitting authorities will allow direct buried conduit systems. All conduits shall have a pull string installed. All conduits shall be capped to prevent debris from entering the conduit.

## EXHIBIT “E”

### PADMOUNT TRANSFORMER BUILDING CLEARANCE STANDARD

The purpose of this document is to provide guidelines for the location of mineral oil-filled padmount transformers outdoors near buildings and equipment. These guidelines specify minimum distances to buildings, building openings, and equipment to provide fire risk protection and adequate working space.

Table 1 below lists the minimum clearances to buildings and building openings. Refer to sections A, B, and C below concerning placement around doors, windows, and air vents (intakes and exhausts). Section D lists allowable distances to specific equipment.

Table 1 – Clearances from Buildings and Building Openings

Type of Construction	Clearance extending out from building*	Side clearance	Height Clearance
Combustible	12 ft		
Non-Combustible	6 ft		
Doors	20 ft	10 ft	
Windows	10 ft	5 ft (See Table 2)	10 ft
Air Vents	20 ft	10 ft (See Table 3)	25 ft

\*habitable and non-habitable buildings

#### Notes:

1. Distances are from the pad or transformer whichever is closer to the building or opening.
2. If the building has an overhang, the distance is measured from the outside edge of the overhang.
3. Outside walkways or stairs attached to the building shall be considered as part of the building. Minimum clearance must also be maintained from walkways used for exit to a place of safety.
4. Avoid placing transformers in front of doors and windows or beneath windows and vents whenever possible.
5. Final grade at the location of the transformer shall provide for mineral oil to drain from the building. Otherwise, an oil containment means is required.
6. Distances less than those specified in Table 1 but not less than the working space required in Section E may be allowed if approved by the appropriate code enforcement authority. This may require alternate means of fire protection per NEC Section 450.27 and NESC Section 152(A)(2) including fire barriers, fire rated walls, sprinkler systems, oil containment means, or other approved measures. Use of alternate means of fire protection must be approved by the local code enforcement authority.
7. It shall be the customer’s responsibility to conform to all local building codes, insurance regulations, or ordinances affecting the transformer location.
8. Combustible/Non-combustible construction type shall be that which is defined by respective state building codes.

**A. Doors, Fire Escapes, or Fire Exits**

Padmounted transformers shall not be located within a zone extending outward 20 feet and 10 feet to the side from any doorway, fire escape, or fire exit. See diagram below.

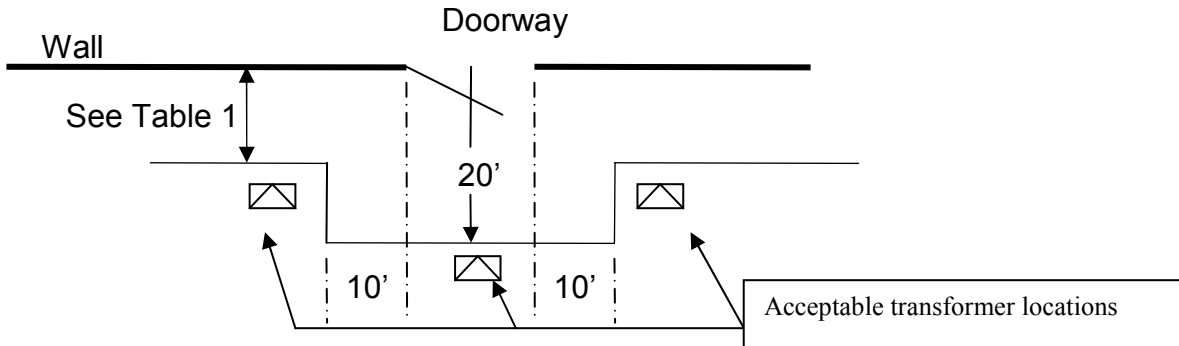

**B. Window or Opening other than an Air Vent**

Where the vertical clearance to a window is less than 10 ft, the mineral oil-filled transformer shall not be located within a zone extending 10 feet outward from the building and 5 feet to the side of the window. See Table 2 below. Where the vertical clearance is 10 ft or greater, the transformer shall not be located within the distance outward from the building wall as determined by building construction type.

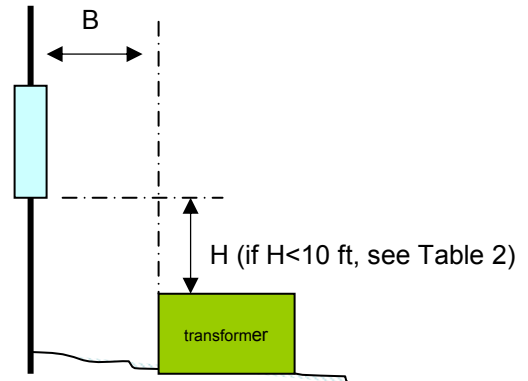
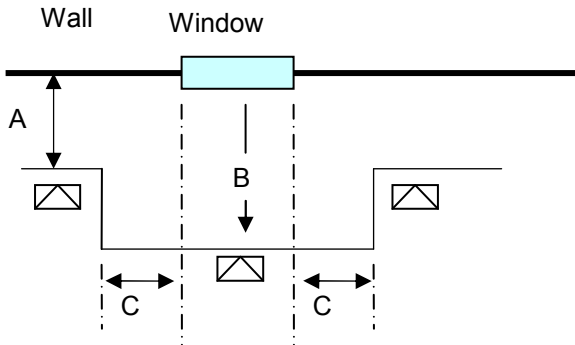

**Table 2 (H < 10ft)**

Type of Construction	A	B	C
Combustible	12 ft	12 ft	---
Non-combustible	6 ft	10 ft	5 ft

### C. Air Vent

Where the vertical clearance to an air vent is less than 25 ft, the mineral oil-filled transformer shall not be located within a zone extending 20 feet outward from the building and 10 feet to the side of the vent. See Table 3 below. Where the vertical clearance is 25 ft or greater, the transformer shall not be located within the distance outward from the building wall as determined by building construction type.

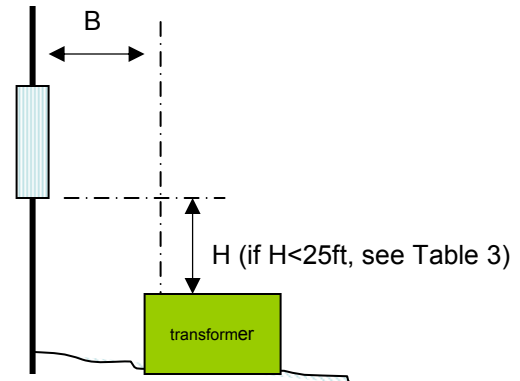
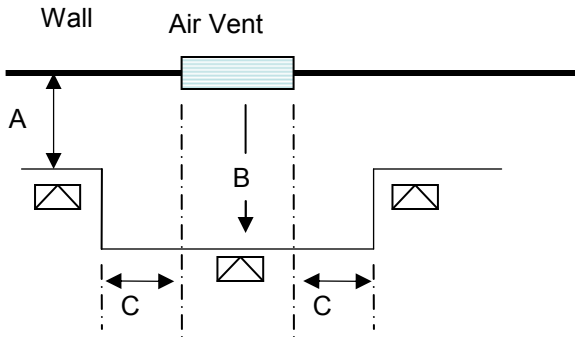

Table 3 (H<25ft)

Type of Construction	A	B	C
Combustible	12 ft	20 ft	10 ft
Non-combustible	6 ft	20 ft	10 ft

### D. Allowable Distances from Equipment

Table 4 – Clearance to Equipment\*

Type of Equipment	Minimum Distance
Containers of flammable liquids or gas. (Oxygen, LP, Gasoline, etc)	20 ft
Generators, customer owned transformers, etc.	6 ft
Fire hydrants, sprinkler valves, standpipes, etc.	6 ft
Natural gas meters	3 ft

\* This is not an all-inclusive list.

### E. Working Space

A minimum clear working space of 3 ft must be maintained from each side of the transformer and a minimum of 10 ft from the front. Where a meter is mounted on a transformer, a clear space around the meter at least 3 ft wide, 4 ft deep, and 8 ft high must be provided and always be available for reading, inspecting, testing, and maintenance operations. Clear space for safe access to and egress from the working space must be maintained.

## EXHIBIT "F"

### INSTALLATION REQUIREMENTS FOR THREE-PHASE PADMOUNT TRANSFORMER FOUNDATIONS FOR COMMERCIAL OR INDUSTRIAL CUSTOMERS

1. **Acceptance:** The company reserves the right to refuse service to new installations that do not meet Duke Energy requirements and may elect to remove existing service cables if the customer fails to provide adequate maintenance to customer-owned facilities

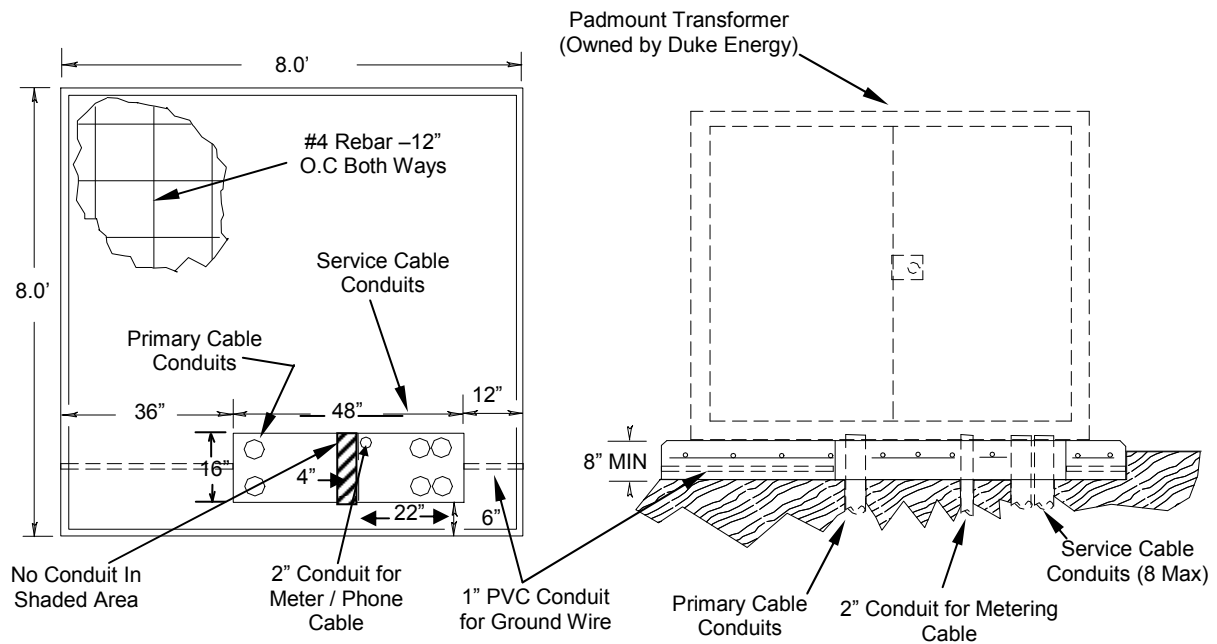

2. **Location:** Duke Energy shall be responsible for determining the final location for the transformer pad. The customer shall provide a level location for a padmount transformer installation as directed by the Company. The three-phase transformer must be located adjacent to and within 10 feet of a driveway or other area accessible to Duke Energy construction and maintenance equipment. No part of the transformer (or transformer pad) may be within 12 feet from any combustible wall, window, or ventilation opening and 20 feet from any doorway in a building. There must be at least of three (3) feet of clearance between customer equipment or landscaping and the side of the transformer (or transformer pad) and 10 feet of clearance to the front of the transformer (or transformer pad).

3. Design: The customer is responsible for constructing a transformer pad in accordance with Duke Energy requirements suitable for the largest transformer that may be required. The customer should consider frost action, drainage and local soil conditions when developing the structural design of the transformer pad. Specific requirements include:
  1. The transformer pad shall be a minimum of eight (8) inches thick. The top surface shall be a minimum of two (2) inches above the surrounding grade. Reinforcing steel shall be at least #4 bars or larger. It shall be installed a minimum of 12 inches O.C. both ways.
  2. The transformer pad shall be installed on a bed of granular fill materials that has been compacted prior to pouring concrete.
  3. The surface of the transformer pad shall be flat, smooth and level within 1.0" in all directions.
  4. The edge of the transformer pad shall have a one (1) inch bevel formed into the top edge.
  5. A one-inch ID PVC conduit shall be installed in the concrete as shown in the sketch for the installation of grounding conductors (by Duke Energy) for adjacent communications equipment (required by the NESC).
4. Materials & Labor: The customer shall provide all materials and excavation labor necessary to install the transformer pad. This includes: excavation, backfilling, installation of conduit and conduit accessories, building forms, pouring and finishing concrete, etc.
5. Conduit: The customer shall install, own and maintain the conduits entering the transformer pad. It shall be installed in accord with Duke Energy standards. The conduit shall be made from either polyethylene (PE) or Polyvinyl Chloride (PVC) and suitable for use with underground electric distribution cables rated at 90°C. All conduits shall have a UL listing and a schedule 40 rating clearly printed on the exterior surface. For primary jacketed concentric neutral primary cables, the minimum inside diameter of the conduit shall be four (4) inches. Duke Energy may require larger sizes. All conduits must have a pull string installed and be capped to prevent debris from getting into the conduit.

# EXHIBIT "G"

## CONSTRUCTION DETAILS FOR CUSTOMER INSTALLED ELECTRIC FACILITIES

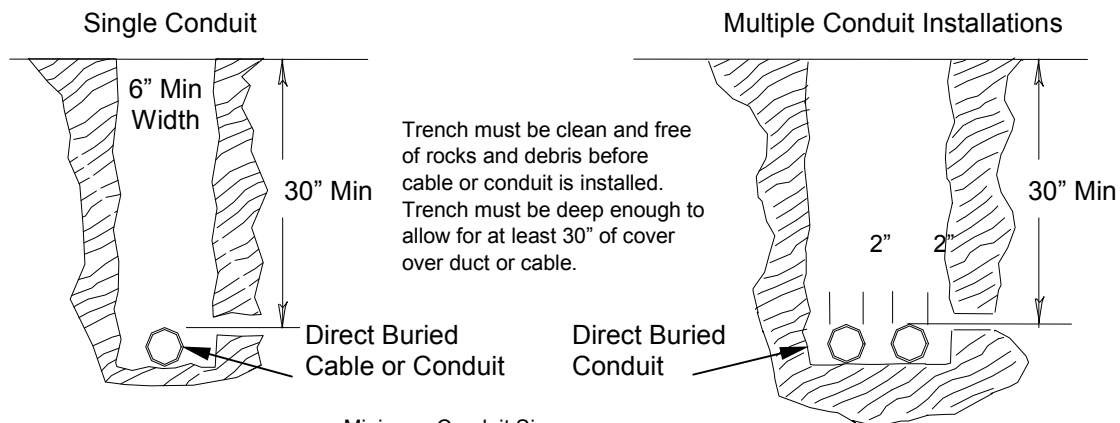

### Minimum Conduit Sizes:

- Residential- 3" ID
  - Commercial- 4" ID for URD Cables
  - Commercial- 6" ID for Power Cables
- All conduits must be UL Listed and have a Schedule 40 (Sch.40) Rating. A 90°C temperature rating is required.

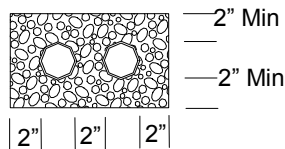
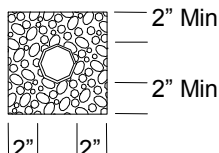

When conduit is concrete encased, the conduit must be covered by a minimum of 2" of concrete on all sides.

### Three-Phase Transformer Boxout Details

Customer to install conduit into pad boxout as shown:

- Primary conduit must be installed as shown.
- Secondary/Service ducts must be installed within the 16" x 22" secondary boxout area. In the detail, there shall be no conduit.
- Conduit should extend at least 3" above the bottom of the boxout but not above the surface of the pad.

Total Box-Out Opening 16" x 48"

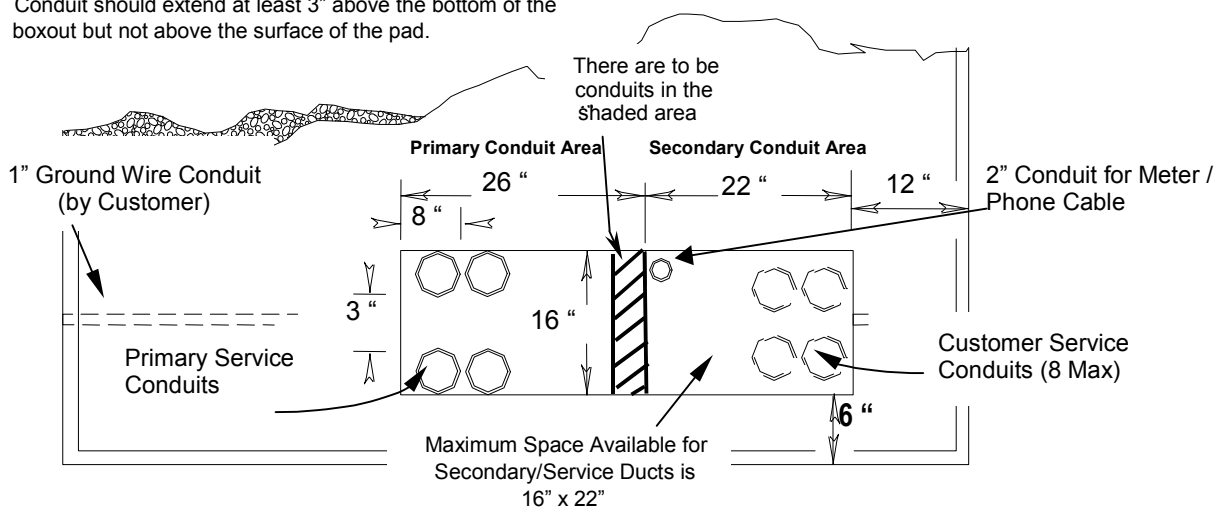

## EXHIBIT "H"

### CONSTRUCTION DETAILS FOR CUSTOMER INSTALLED ELECTRIC FACILITIES PADMOUNT EQUIPMENT PROTECTION

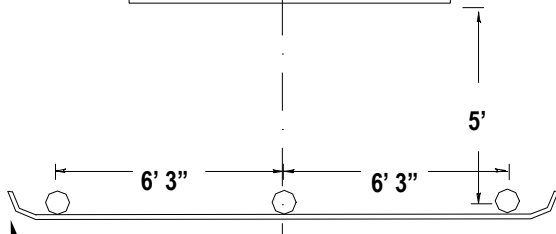
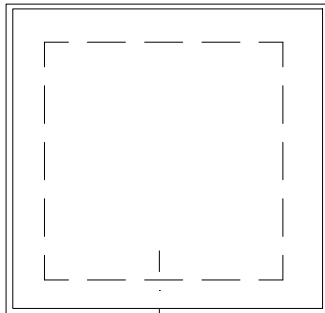
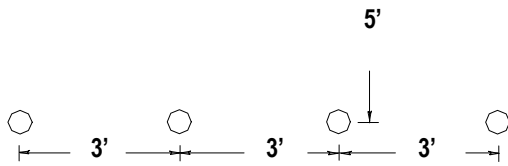
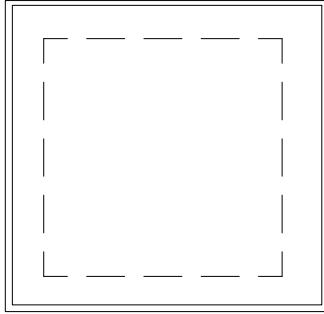

Terminal ends on guard rail barriers are optional

Highway "Flex-Beam" guardrail (10 or 12 ga.)

Guard posts must be spaced to allow unrestricted access to the primary compartment of the transformer. Consult with the Duke Energy Representative for proper spacing and placement.

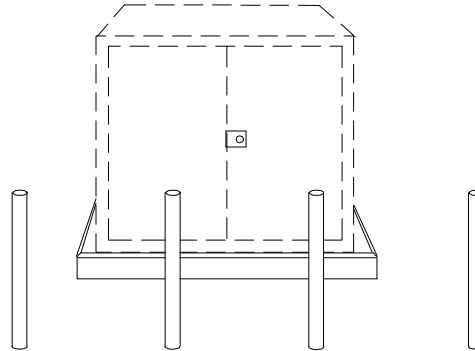

Protective posts may be 4" - 6" steel pipe. All must be filled with concrete.

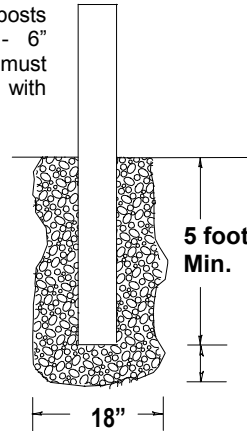

Height of protection post will vary depending on the installation.

- For bare posts with no crosspieces - Minimum Height is 3.0'
- For posts with crosspieces - Minimum Height is 2.5'

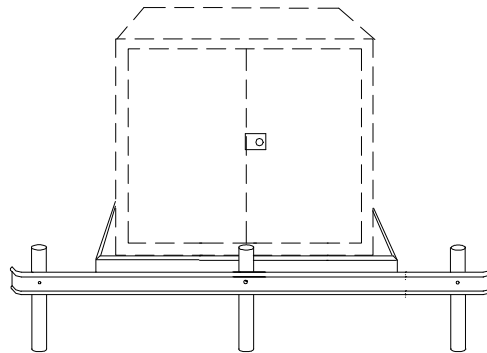

Protective posts or barriers may also be required along the sides of Duke Energy owned padmount equipment. Side protection shall be located at least 3 feet away from the back or sides of the equipment cabinet or as directed by the Duke Energy representative.